

• Permanent operation <i>Service permanent</i>	
• Main contact <i>Contact principal</i>	2 PNO - DM 2 T (DE)
• Auxiliary contacts <i>Contacts auxiliaires</i>	1 NO + 1 NC 1R (DC) + 1T (DE)
• Coil supply <i>Alimentation bobine</i>	Direct current Courant continu
• Related standard <i>Normes de référence</i>	AIR 7304 AIR 8456B

Application notes:
102-Relays and temperature variations

PRINCIPAL TECHNICAL CHARACTERISTICS CARACTERISTIQUES TECHNIQUES PRINCIPALES

• Contacts rated at <i>Prévu pour commuter</i>	200 Amps 28 Vdc 200 A / 28 Vcc
• Weight <i>Masse</i>	P/N 106 : 450 g ±5% P/N S106 : 470 g ±5% P/N M106 : 480 g ±5%
• Overall size <i>Dimensions hors tout</i>	103 x 65 x 51 mm max
• Metal body <i>Corp métallique</i>	
• Special models available upon request <i>Modèles spécifiques sur demande</i>	

CONTACT ELECTRICAL CHARACTERISTICS CARACTERISTIQUES ELECTRIQUES DES CONTACTS/POUVOIR DE COUPURE

Contact rating per load type, main contact <i>Contact principal par type de charge</i>	28 Vcc	
Resistive / Résistif	200 (In)	
Inductive / Inductif (L/R=5ms)	100A	
Motor / Moteur	200A	
Overload / Surcharge	600A	
I minimum / I minimum	20A	
Contact rating per load type, auxiliary contact <i>Contact auxiliaire par type de charge</i>	28 Vcc	115 Vca – 400 Hz
Resistive / Résistif	5A	4A
Inductive / Inductif (L/R=5ms)	3A	2A
Lamp / Lampe	1A	0.5A

LEACH INTERNATIONAL EUROPE S.A.S.
Tel: +33 3 87 97 98 97
Fax: +33 3 87 97 96 86

LEACH INTERNATIONAL ASIA PACIFIC
Tel: +852 2 191 3830
Fax: +852 2 389 5803

The technical information provided by Leach International Europe is to be used as a guide only, and is not meant for publication or as documentation for altering any existing specification. Dimensions are in millimeters unless otherwise specified. Rev. 02/2025.

COILS CHARACTERISTICS (Vdc) [1]
CARACTERISTIQUES DES BOBINES (Vcc) [1]

Nominal voltage Tension nominale	28 Vdc
Maximum voltage Tension maximum	32 Vdc
Maximum pickup voltage Tension max. d'enclenchement assuré	18 Vdc (-15°C to +70°C) 21Vdc (-55°C to +80°C)
Dropout voltage Tension de déclenchement	2 Vdc min. 8 Vdc max.
Inrush current Courant de d'appel @ 25°C	9A max. at 28 Vdc
Hold current Courant de maintien @ 25°C	200 mA max at 28 Vcc
Coil suppression (max Vdc) Circuit écrêteur(Vcc max)	-65V

GENERAL CHARACTERISTICS
CARACTERISTIQUES GENERALES

Temperature range <i>Gamme de température</i>	-55°C to +80°C
Life at nominal load <i>Durée de vie minimale sous charge nominale</i>	50,000 cycles
Dielectric strength at sea level (main contacts) <i>Rigidité diélectrique au niveau de la mer (contacts principaux)</i>	1 500 Vrms
Insulation resistance at 500 Vdc <i>Résistance d'isolement sous 500 Vcc</i>	100 M Ω min.
Sinusoidal vibrations <i>Vibrations sinusoïdales</i>	10 G / 5 to 2000 Hz
Shocks <i>Chocs</i>	30 G / 11 ms
Maximum contact opening time under vibrations and shocks <i>Durée max. d'ouverture des contacts sous l'influence des vibrations et chocs</i>	10 μ s
Maximum operate time at 28 Vdc <i>Temps d'enclenchement sous 28 Vcc</i>	20 ms max at 20°C
Maximum release time at 28 Vdc <i>Temps de déclenchement sous 28 Vcc</i>	15 ms max at 20°C
Main contact voltage drop <i>Chute de tension dans le contact principal</i>	
- Initial value <i>Valeur initiale</i>	120mV
- After endurance test <i>Après test d'endurance</i>	200 mV
Auxiliary contact voltage drop <i>Chute de tension dans les contacts auxiliaires</i>	
- Initial value <i>valeur initiale</i>	60 mV max
- After endurance test <i>Après test d'endurance</i>	120 mV max
Auxiliary contacts <i>Contacts auxiliaires</i>	
- Contact resistance (low level) <i>Résistance de contact (bas niveau)</i>	1 Ω
- I minimum <i>I minimum</i>	50 mA
Assembly torque <i>I Couple de serrage</i>	
- Main contact terminals <i>Bornes de puissance</i>	2.45 Nm
- Coil and auxiliary contact terminals <i>Bornes de la bobine et des contacts auxiliaires</i>	1.2 Nm

Dimensions in mm
Tolerances, unless otherwise specified, $\pm 0.5\text{mm}$

MOUNTING STYLES [1] TYPE DE CONFIGURATION [1]

206 = WITHOUT BASE AND CLAMP / SANS SOCLE NI COLLIER
S 206 = WITH BASE AND CLAMP / AVEC SOCLE ET COLLIER
M 206 = WITH MOULDED BODY / AVEC SOCLE MONOBLOC

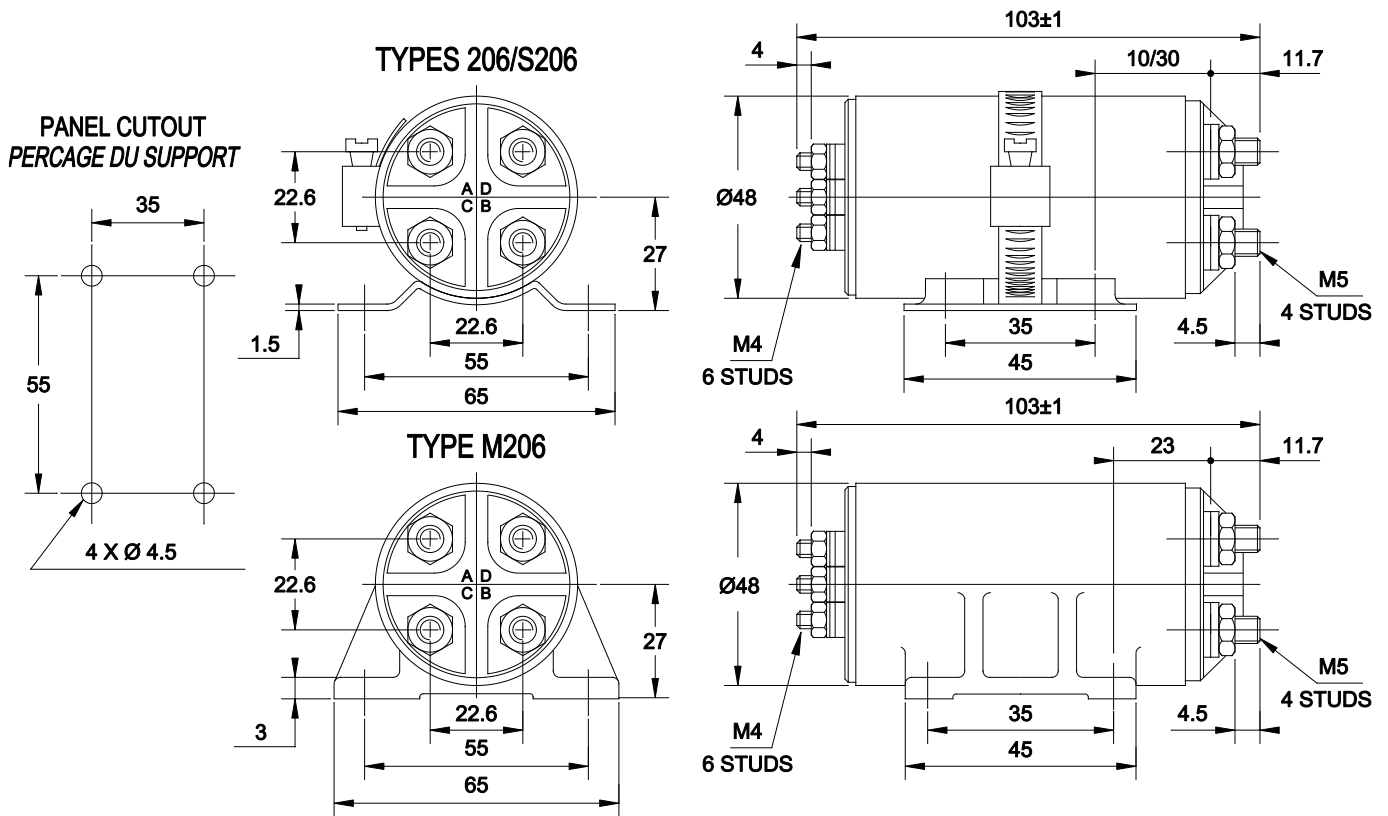

TERMINAL TYPES [1] RACCORDEMENT ÉLECTRIQUE [1]

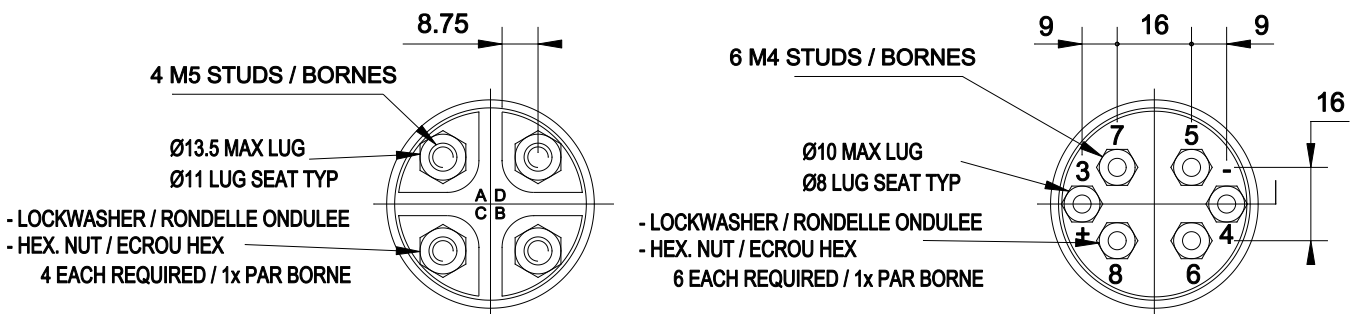

**POWER MAIN CONTACTS
CONTACTS PRINCIPAUX**

**COIL TERMINALS / AUXILIARY CONTACTS
BORNES BOBINE / CONTACTS AUXILIAIRES**

SCHEMATIC DIAGRAM [1]
SCHEMA [1]

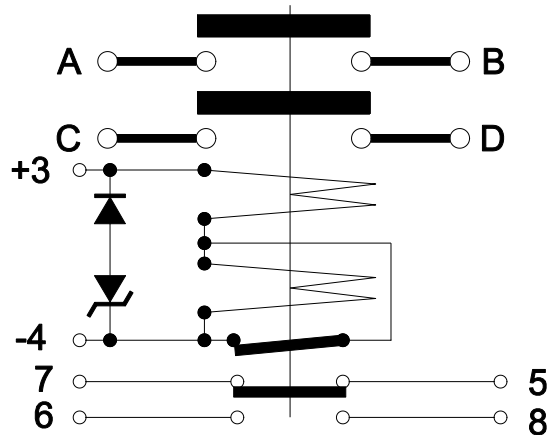

REFERENCE SYSTEM
SYSTEME DE REFERENCES

Mounting style | Code de fixation (M,S)

- Basic series designation | Référence de base**

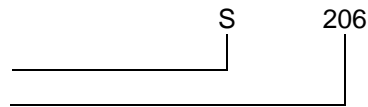

Exemple : M206

NOTES
REMARQUES

- Other configurations may be possible. Please contact factory**
D'autres configurations peuvent être possibles : Nous consulter.