



• Permanent operation <i>Service permanent</i>	
• Main contact <i>Contact principal</i>	1 PNO - DM 1 T (DE)
• Auxiliary contacts <i>Contacts auxiliaires</i>	2 NO + 2 NC 2R (DC) + 2T (DE)
• Coil supply <i>Alimentation bobine</i>	Direct current Courant continu
• Polarized and protected coil <i>Circuit écrêteur incorporé</i>	See schematic diagram Voir schéma
• Related standard <i>Normes de référence</i>	AIR 7304 AIR 8456B AIR 9456

Application notes:
102

PRINCIPAL TECHNICAL CHARACTERISTICS CARACTERISTIQUES TECHNIQUES PRINCIPALES

• Contacts rated at <i>Prévu pour commuter</i>	700 Amps 28 Vdc 700 A / 28 Vcc
• Weight <i>Masse</i>	P/N M708 : 2025 g ±10%
• Overall size <i>Dimensions hors tout</i>	162 x 98 x 76.5 mm max
• Metal body <i>Corp métallique</i>	
• Special models available upon request <i>Modèles spécifiques sur demande</i>	

CONTACT ELECTRICAL CHARACTERISTICS CARACTERISTIQUES ELECTRIQUES DES CONTACTS/POUVOIR DE COUPURE

Contact rating per load type, main contact <i>Contact principal par type de charge</i>	28 Vcc
Resistive / Résistif	700 (In)
Inductive / Inductif (L/R=5ms)	400A
Overload / Surcharge	3 000A
I minimum / I minimum	10A
Contact rating per load type, auxiliary contact <i>Contact auxiliaire par type de charge</i>	28 Vcc
Resistive / Résistif	3A
Inductive / Inductif (L/R=5ms)	2A
Lamp / Lampe	1.5A

LEACH INTERNATIONAL EUROPE S.A.S.

Tel: +33 3 87 97 98 97

Fax: +33 3 87 97 96 86

LEACH INTERNATIONAL ASIA PACIFIC

Tel: +852 2 191 3830

Fax: +852 2 389 5803

The technical information provided by Leach International Europe is to be used as a guide only, and is not meant for publication or as documentation for altering any existing specification. Dimensions are in millimeters unless otherwise specified. Rev. 06/2019.

COILS CHARACTERISTICS (Vdc) [1] CARACTERISTIQUES DES BOBINES (Vcc) [1]

Nominal voltage Tension nominale	28 Vdc
Maximum voltage Tension maximum	32 Vdc
Maximum pickup voltage Tension max. d'enclenchement assuré	13Vdc at +20°C 18Vdc at +125°C
Dropout voltage Tension de déclenchement	4 Vdc min. 9 Vdc max.
Inrush current Courant d'appel @ 25°C	6A at 28 Vdc
Hold current Courant de maintien @ 25°C	<340 mA at 28 Vcc
Coil suppression (max Vdc) Circuit écrêteur (Vcc max)	-80

GENERAL CHARACTERISTICS CARACTERISTIQUES GENERALES

Temperature range Gamme de température	-55°C to +125°C
Life at nominal load Durée de vie minimale sous charge nominale	50,000 cycles
Dielectric strength at sea level, main contact Rigidité diélectrique au niveau de la mer, contact principal	1 500 Vrms
Insulation resistance at 500 Vdc Résistance d'isolement sous 500 Vcc	100 M Ω min.
Sinusoidal vibrations Vibrations sinusoïdales	10 G / 5 to 2000 Hz
Shocks Chocs	50 G / 11 ms
Maximum contact opening time under vibrations and shocks Durée max. d'ouverture des contacts sous l'influence des vibrations et chocs	10 µs
Maximum operate time at 28 Vdc Temps d'enclenchement sous 28 Vcc	30 ms max at 20°C
Maximum dropout time at 28 Vdc Temps de déclenchement sous 28 Vcc	25 ms max at 20°C
Main contact voltage drop Chute de tension dans le contact principal	
- Initial value Valeur initiale	150mV
- After endurance test Après test d'endurance	220 mV
Auxiliary contact voltage drop Chute de tension dans les contacts auxiliaires	
- Initial value valeur initiale	60 mV max
- After life Après test d'endurance	120 mV max
Auxiliary contacts Contacts auxiliaires	
- Contact resistance (low level) Résistance de contact (bas niveau)	1 Ω
- I minimum I minimum	10 mA
Assembly torque Couple de serrage	
- Main contact terminals Bornes de puissance	14.7 Nm

MOUNTING STYLES [1]
TYPE DE CONFIGURATION [1]

Dimensions in mm
Tolerances, unless otherwise specified, $\pm 0.5\text{mm}$

TYPE M708

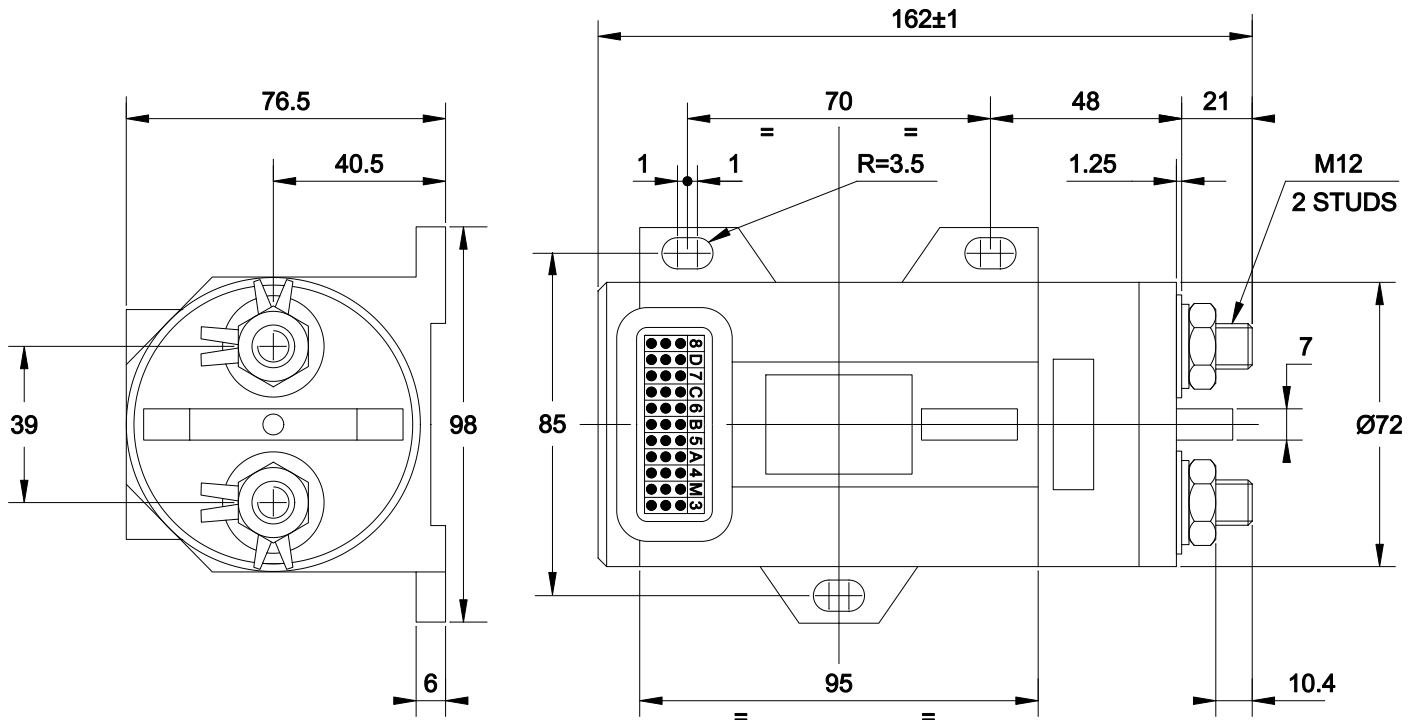

TERMINAL TYPES [1]
RACCORDEMENT ELECTRIQUE [1]

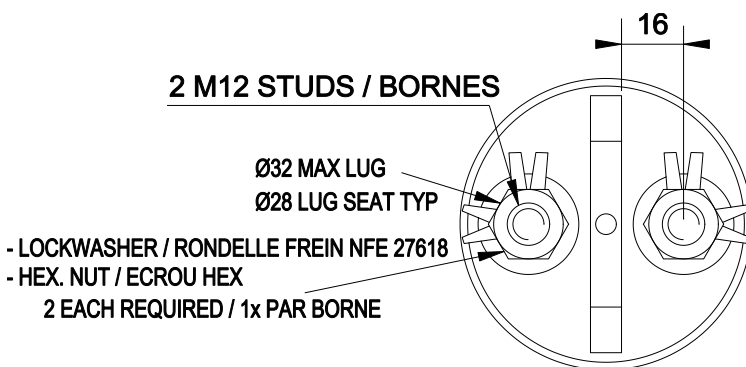

MAIN CONTACT
CONTACT PRINCIPAL

CONNECTION: NAS1599
CONTACTS (3 POINTS)

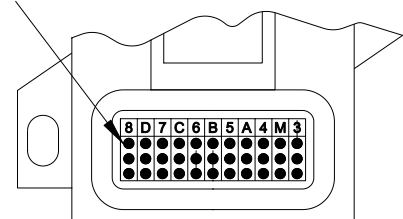

COIL TERMINALS / AUXILIARY CONTACTS
BORNES BOBINE / CONTACTS AUXILIAIRES

SCHEMATIC DIAGRAM [1]
SCHEMA [1]

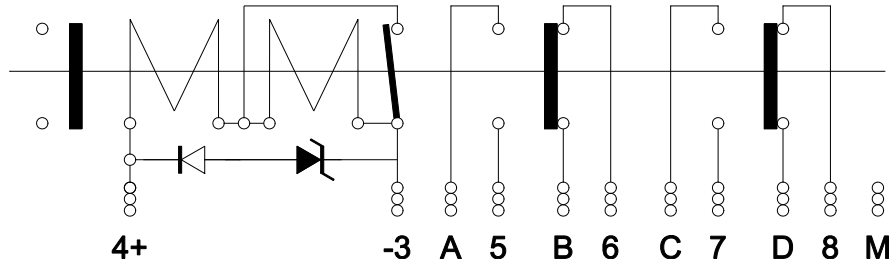

REFERENCE SYSTEM
SYSTEME DE REFERENCES

Mounting style | Code de fixation (M, S)

- Basic series designation | Référence de base**

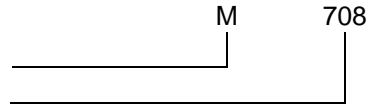

Exemple : M708

NOTES
REMARQUES

- [1] Other configurations may be possible. Please contact factory**
D'autres configurations peuvent être possibles : Nous consulter.