



- **Polarized, non-latching hermetically sealed relay**
Relais hermétique monostable polarisé

- **Contact arrangement**
Combinaison des contacts

6 PDT
6 RT

- **Coil supply**
Alimentation bobine

Direct current
Courant continu

- **Qualified or in accordance with**
Qualifié selon ou en accord avec

EN 116000-3 / MIL-PRF-83536

- **Railway compliancy**
Conformité ferroviaire

NF F 62002
IEC 60077 / EN 50155
IEC 61373
EN 50121-3-2
IEC 61810-3
EN45545-2 / NFPA 130

Application notes:

001-Correction due to coil copper wire resistance change in temperature

003-Life capability versus voltage

007-Suppressor devices for relay coils

Applicable sockets:

SF600-2F
SFE*7*
SHKE
SF*CE40E-*

PRINCIPAL TECHNICAL CHARACTERISTICS CARACTERISTIQUES TECHNIQUES PRINCIPALES

- **Nominal current**
Courant nominal **12 Amps**
12 A

- **Weight**
Masse 110 g max

- **Dimensions of case**
Dimensions du boîtier 26 x 25.7 x 37.7 mm max

- **Balanced-force design, all welded construction**
Armature à forces équilibrées

- **Hermetically sealed, corrosion protected metal can**
Boîtier métallique hermétique protégé anti-corrosion

- **No make before break**
Non chevauchement des contacts

- **Specific models available upon request**
Modèles spécifiques sur demande

CONTACT ELECTRICAL CHARACTERISTICS / CONTACT RATING CARACTERISTIQUES ELECTRIQUES DES CONTACTS / POUVOIR DE COMMUTATION

Minimum operating cycles <i>Durée de vie minimale</i>	Nominal contact voltage (Vdc) <i>Tension aux bornes du contact (Vcc)</i>	Resistive load <i>sur charge résistive</i>	inductive load <i>sur charge inductive load (L/R=30ms)</i>	Level <i>Niveau</i>
1 000 000 cycles	72 V	1A	0,6A	High level Fort niveau
2 000 000 cycles	5 ≤ U ≤ 140 V	1 à 20mA	1 mA à 10 mA	Low level Fort niveau
2 000 000 cycles	15 ≤ U ≤ 35 V	20 mA à 2,5 A	10 mA à 1,5 A	High level Fort niveau
2 000 000 cycles	35 ≤ U ≤ 90 V	20 mA à 0,9 A	10 mA à 0,5 A	High level Fort niveau
2 000 000 cycles	90 ≤ U ≤ 140 V	20 mA à 0,7 A	10 mA à 0,35 A	High level Fort niveau

LEACH INTERNATIONAL EUROPE S.A.S.

Tel: +33 3 87 97 98 97

Fax: +33 3 87 97 96 86

LEACH INTERNATIONAL ASIA PACIFIC

Tel: +852 2 191 3830

Fax: +852 2 389 5803

The technical information provided by Leach International Europe is to be used as a guide only, and is not meant for publication or as documentation for altering any existing specification. Dimensions are in millimeters unless otherwise specified. Rev. 03/2025.

COIL CHARACTERISTICS (Vdc)
CARACTERISTIQUES DES BOBINES (Vcc)

CODE	C	H	B	J	A	D	E	W	V
Nominal operating voltage <i>Tension nominale (Un)</i>	6	9	12	18	24	36	48	72	110
Maximum operating voltage at +85°C <i>Tension maximale à +85°C</i>	7.5	11.3	15	22.5	33	45	60	90	138
Minimum operating voltage at +70°C, coil previously energized at 1.15 Un or at 35°C coil previously energized at Un <i>Tension minimale du domaine d'action bobine alimentée préalablement à 1,15 Un à +70°C, ou bobine alimentée préalablement à Un à +85°C</i>	4.2	6.3	8.4	12.6	18.5	25.2	33.6	50.4	77
Hold voltage at +85°C <i>Tension de non relachement à +85°C</i>	2.6	3.2	4.2	6.3	7.5	12.5	17.5	22.5	35
Drop-out voltage at -40°C <i>Tension de relachement assuré à -40°C</i>	0.3	0.45	0.6	0.9	1.5	1.8	2	3.6	5.5
Coil resistance in Ohms ±10% at +25°C <i>Résistance de la bobine en Ohms ±10% à +25°C</i>	10	22	40	90	210	350	620	1300	3200
Maximum back EMF (Volts) (with P suffix) <i>Tension maximale d'écrêtage (avec lettre P finale)</i>	/	/	/	-42	-42	-55	-70	-100	-150

GENERAL CHARACTERISTICS
CARACTERISTIQUES GENERALES

Temperature range / Gamme de temperature	-40°C à +85°C
Dielectric strength at sea level / Rigidity diélectrique au niveau de la mer - Contacts to ground and between contacts / Entre contacts et boîtier et entre les contacts - Coil to ground / Entre bobine et boîtier	1500 Vrms / 50 Hz 1500 Vrms / 50 Hz
Initial insulation resistance at 500 Vdc / Résistance d'isolement initiale sous 500 Vcc	100 M Ω min.
Sinusoidal vibration / Vibrations sinusoïdales	IEC 61373, Category 1, Class B
Mechanical shock / Chocs mécaniques	IEC 61373, Category 1, Class B
Maximum contact opening time under vibration and shock <i>Durée maximum d'ouverture des contacts sous l'influence des vibrations et chocs</i>	10 μ sec
Operate time at nominal voltage / Temps d'enclenchement sous tension nominale	15 ms max
Release time / Temps de déclenchement	15 ms max
Bounce time / Temps de rebonds	1 ms max
Contact resistance at 5 Amps / Résistance de contact sous courant 5 A	15 mΩ max
Damp heat / Chaleur humide	IEC 60068-2-67, Test condition 1
Salt mist / Brouillard Salin	IEC 60068-2-11, 96h
Fire & Smoke / Feu fumée	NF F 16-101/102 ; EN45545-2
REACH & Rohs	Refer to REACH and RoHS associated certificates

SCHEMATIC DIAGRAM SCHEMAS

BOTTOM VIEW, DE-ENERGIZED COIL
VUE DE DESSOUS, BOBINE NON ALIMENTEE

P OPTION

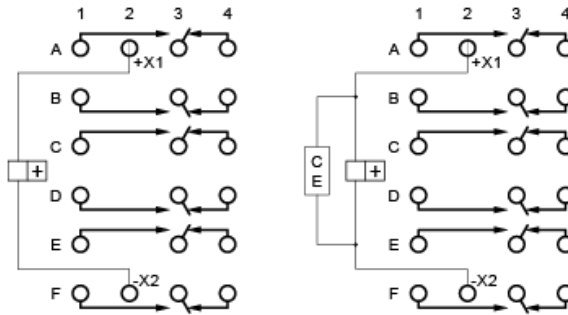

CE: SUPPRESSOR DEVICE
CE: CIRCUIT ECRETEUR BOBINE

NUMBERING SYSTEM SYSTEME DE REFERENCES

Basic series designation | Référence de base

1. Mounting styles | Type de fixations (A, B, C, D, H, J, K)
2. Terminal types | Type de sorties (1, 2, 4, 8)
3. Coil voltage | Code bobine (C, H, B, J, A, D, E, W, V)
4. Coil Suppressor (P) | Voir remarque 4 ci-dessous
5. Coding keys for H mounting style
Clés de codage pour fixation H

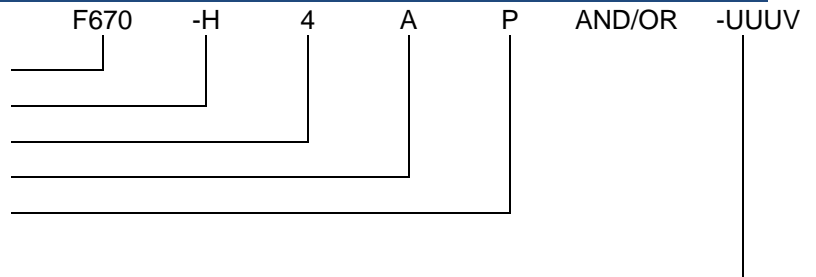

Example F670-H4AP-UUUV

NOTES REMARQUES

1. Relays with B, D, H mounting and terminal 4 are compatible with socket families SF600-2F, SFE*7*, SHKE and SF*CE40E*.
*Les relais avec les fixations B, D, H et la sortie 4 sont compatibles avec les socles des familles SF600-2F, SFE*7*, SHKE et SF*CE40E*.*
2. Isolation spacer pads for PCB mounting available on request, other spacer pads are available.
Possibilité de cales isolantes, pour montage PCB. Autres cales nous consulter.
3. For other mounting styles or terminal types, please contact the factory
Autres fixations ou sorties sont disponibles : nous consulter.
4. Non-overlapping arrangement insures that if one of the NO or NC contacts is accidentally welded, none of the other contacts can be transferred to another state.
Le non chevauchement des contacts est garanti par construction. Si un contact est accidentellement collé en position travail ou repos, aucun des autres contacts ne peut se fermer dans l'état opposé.
5. Qualification and quality levels : Contact the factory
Niveaux de qualification et de qualité : Nous consulter.
6. Coil time constant L/R : 11ms
Constante de temps L/R des bobines : 11ms
7. Recommended torque level for screws M3 or 4.40 UNC: 0,45Nm
Couple de serrage recommandé pour M3 ou 4.40 UNC : 0,45Nm

CODING CHART FOR H MOUNTING WITHOUT COIL SUPPRESSION TABLEAU DE CODAGE POUR FIZATION H SANS CIRCUIT SUPPRESSEUR

Type of contact operation			Nominal load voltage				
Pole	Low level	High level	24 volts	48 volts	72 volts	110 volts	36 volts
A		X	UUUV	VUUU	WUUU	XUUU	YUUU
B		X					
C		X					
D		X					
E		X					
F		X					
A		X	UUUU	VUUU	WUUU	XUUU	YUUU
B	X						
C		X					
D		X					
E		X					
F		X					
A	X		UUUU	VUUU	WUUU	XUUU	YUUU
B	X						
C		X					
D		X					
E		X					
F		X					
A	X		UUUU	VUUU	WUUU	XUUU	YUUU
B	X						
C		X					
D		X					
E		X					
F		X					
A	X		UUUU	VUUU	WUUU	XUUU	YUUU
B	X						
C		X					
D		X					
E		X					
F		X					
A	X		UUUU	VUUU	WUUU	XUUU	YUUU
B	X						
C		X					
D		X					
E		X					
F		X					
A	X		UUUU	VUUU	WUUU	XUUU	YUUU
B	X						
C		X					
D		X					
E		X					
F		X					
A	X		UUUU	VUUU	WUUU	XUUU	YUUU
B	X						
C		X					
D		X					
E		X					
F		X					
A	X		UUUU	VUUU	WUUU	XUUU	YUUU
B	X						
C		X					
D		X					
E		X					
F		X					
A	X		UUUU	VUUU	WUUU	XUUU	YUUU
B	X						
C		X					
D		X					
E		X					
F		X					

RAILWAY COMPLIANCY
CONFORMITE FERROVIAIRE

NF F 62002-1 / NF F 62002-2	Railway rolling stock – all or nothing contact relay and its fixed connector. <i>Matériel roulant ferroviaire – Relais de tout ou rien à contact et embase</i>
EN 50155	Railway applications – Rolling stock – Electronic equipment. <i>Applications ferroviaires – Equipements électroniques utilisés sur le matériel roulant</i>
IEC 60077	Railway applications – Electric equipment for rolling stock – Part 1: General service conditions and general rules <i>Applications ferroviaires – Equipements électriques du matériel roulant – Partie 1 : Conditions générales de service et règles générales.</i>
IEC 61373	Railway applications – Rolling stock – Shock and vibration tests. <i>Applications ferroviaires - Matériel roulant - Essais de chocs et vibrations</i>
EN 50121-3-2	Railway applications – Rolling stock – Electromagnetic compatibility. <i>Applications ferroviaires. Compatibilité électromagnétique</i>
IEC 61810-3	Electromechanical elementary relays - Part 3: Relays with forcibly guided (mechanically linked) contacts. <i>Relais électromécaniques élémentaires - Partie 3 : relais à contacts guidés (liés mécaniquement)</i>
EN45545-2	Railway applications – Fire protection on railway vehicles – Part 2: Requirements for fire behavior of materials and components <i>Applications ferroviaires - Protection contre les incendies dans les véhicules ferroviaires - Partie 2 : exigences du comportement au feu des matériaux et des composants</i>
NFPA 130	Standard for fixed guideway transit and passenger rail systems <i>Norme pour les systèmes fixes des transports en commun et des trains transportant des voyageurs</i>